

DAC8 / DAC8R Direct Access Controller

MANUAL M102942-R 4/07

BASE

Page 1 of 4

Installation and Operations Manual

Micro-Series

Features

- Distributes Door Lock Power to 8 Fused or PTC Outputs
- Outputs directly controlled by Access Control System
- Fail-Safe or Fail-Secure selectable per Output
- FACP Interface for Emergency Power Disconnect
- Replaceable Disconnect Relay with Aux Contact
- Small Footprint PCB - 3.0"w x 6.0"h
- Includes Mounting Hardware



UL 294 Access Control Subassembly

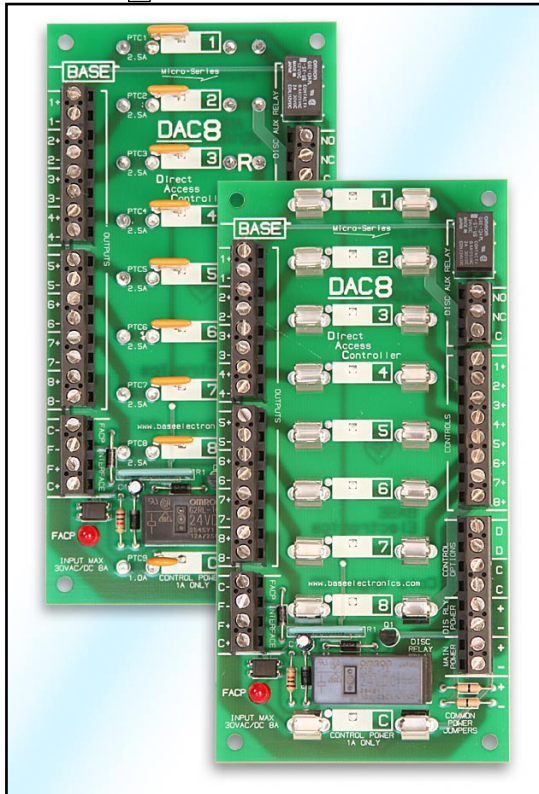

DAC8	Includes (8) 2.0 A replaceable fuses, standard 3AG (1/4" x 1 1/4")
DAC8R	Includes (8) 2.5 A PTC auto-resettable fuses

! WARNING Turn off all power feeding the module terminals before servicing or changing input/output wiring, removing or replacing fuses, etc. Failure to observe this warning may cause electrical shock hazard or may damage internal or external circuit components.

Install in accordance with all applicable sections of the National Electrical Code and other State or Local Regulations.

INSTALLATION

Locate the unit inside a UL Listed enclosure, such as a BASE LVPC Power Cabinet or Econo•Box, close to the source power supply. Drill or punch (4) 0.187" diameter holes (3/16) to match the (4) corner holes in the printed circuit board. Push the nylon standoffs supplied into each hole and snap the module into place.

Note: To comply with UL294 - Standard for Safety - Access Control System Units and the limitations of the product UL Listing, the module should be located within the same room as the associated Access Control equipment and interconnect cabling to the module control inputs. The unit is to be powered from a Class 2 Power-Limited UL Listed Source.

POWER SUPPLY WIRING

Common Power Supply for Outputs and Disc Relay Control
Do not cut Common Power Jumpers. Connect 12 or 24VDC power supply input leads to the **MAIN POWER** input terminals at the lower right side of the module. See Power Input Wiring Diagram 1.

Separate Power Supplies for Outputs and Disc Relay Control
Cut both Common Power Jumpers. Connect 12 or 24VDC Relay Control power supply input leads to the **DIS RLY POWER** input terminals at the lower right side of the module.

Connect 12-24VAC/DC Door Lock power supply input leads to the **MAIN POWER** input terminals at the lower right side of the module. See Power Input Wiring Diagram 2.

www.baseelectronics.com

Go!

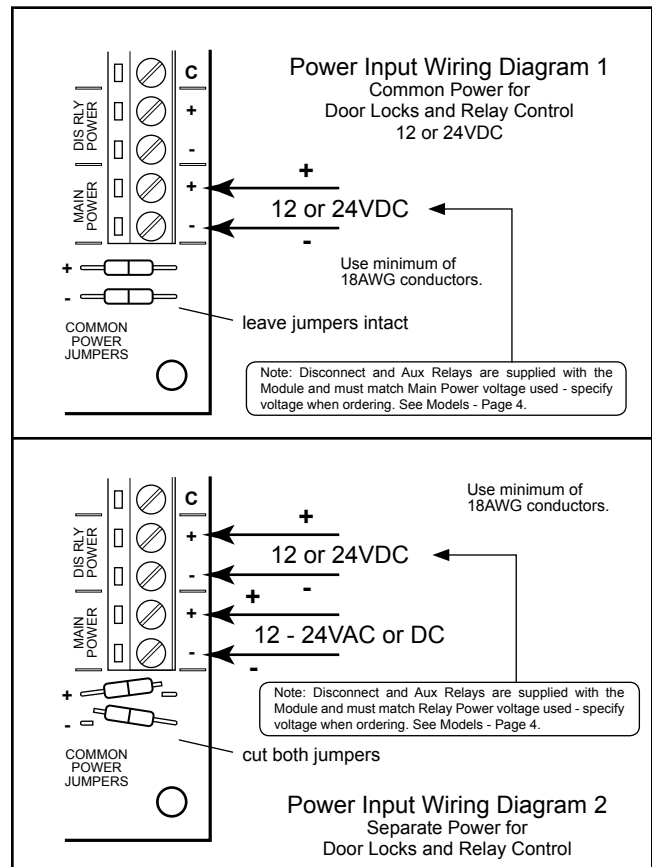

DAC8 / DAC8R Direct Access Controller

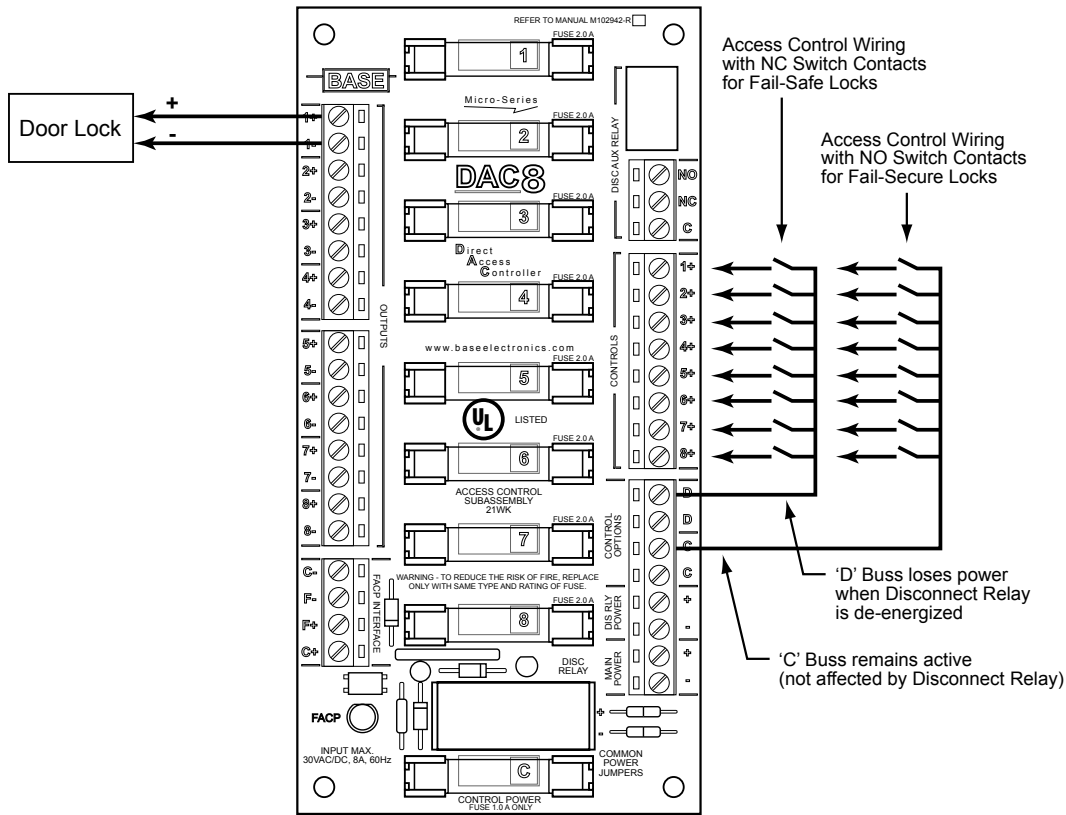

OUTPUT WIRING

Connect wiring to door locks and other output devices at the **OUTPUTS** terminals on the left side on the module as shown above. Output device current rating must be 2.5 Amps or less (for DAC8R) or 2.0 Amps or less (for DAC8).

When powering devices over considerable distances, the cabling resistance may be so high that the voltage available at the device drops to an unacceptable level. To prevent this from occurring, the system cabling should be designed with adequate sized conductors.

DISCONNECT RELAY, AUX RELAY AND TERMINALS

The Disconnect Relay is operated by the FACP Interface. When the FACP Interface is normal, this relay will be energized and will de-energize to drop power for Fail-Safe output devices when the FACP is in alarm. The Red **FACP** LED lights when this relay is energized.

A Disconnect Aux Relay is also provided at the upper right and mirrors the operation of the main Disconnect Relay. Terminals of the Aux relay dry contacts are provided and can be monitored to sense when the Disconnect Relay has changed state. Aux Relay contacts are rated at 2 Amps. Disc and Aux maximum current draw is 70 mA. and is fused by the 1A **CONTROL POWER** fuse.

CONTROL WIRING

Wire Access Control System outputs to **CONTROLS** terminals as shown at above right.

Fail-Safe Control

Use normally-closed contacts for controlling Fail-Safe output devices. Two 'D' terminals are provided for the Common switch leg that will lose power when the Disconnect Relay de-energizes. D = Disconnect Bus

Fail-Secure Control

Use normally-open contacts for controlling Fail-Secure output devices. Two 'C' terminals are provided for the Common switch leg that are not affected by the Disconnect Relay. C = Continuous Bus

Continuously Powered Fused Output

Wire a jumper from a 'C' terminal directly to a control + terminal to obtain a continuously powered fused output.

Fail-Safe Powered Fused Output

Wire a jumper from a 'D' terminal directly to a control + terminal to obtain a powered fused output that will lose power when the Disconnect Relay de-energizes.

DAC8 / DAC8R Direct Access Controller

FACP INTERFACE WIRING AND OPTIONS

Choose the FACP Interface wiring method at right that is appropriate for your installation. If only one DAC8 module is being used, then wiring shown to the next module(s) can be ignored. Maximum current draw of FACP Interface circuitry (F+ and F- terminals) is 10 mA.

FINAL CHECKS BEFORE POWER UP

Before powering the unit, check all wiring and verify that the Disconnect and Aux relays are of the proper voltage and seated in their sockets. The main Disconnect Relay socket includes a simple plastic retainer clip which should be used to properly secure the relay pins in the socket. The Aux relay fits well enough in its socket to eliminate the need for a retaining clip.

RELAY REPLACEMENT

Both the main Disconnect Relay and Aux Disconnect Relay are depluggable and replaceable. Inexpensive replacements are available from several manufacturers and are stocked by BASE. Specify Relay Voltage when ordering - 12 or 24vdc.

FUSE REPLACEMENT

Replace output fuses only with similar 3AG-type fuses, slow or fast blow, with a current trip rating of 2.0 Amps or less if desired. Replace Control Fuse only with 3AG-type 1.0 Amp. fuse.

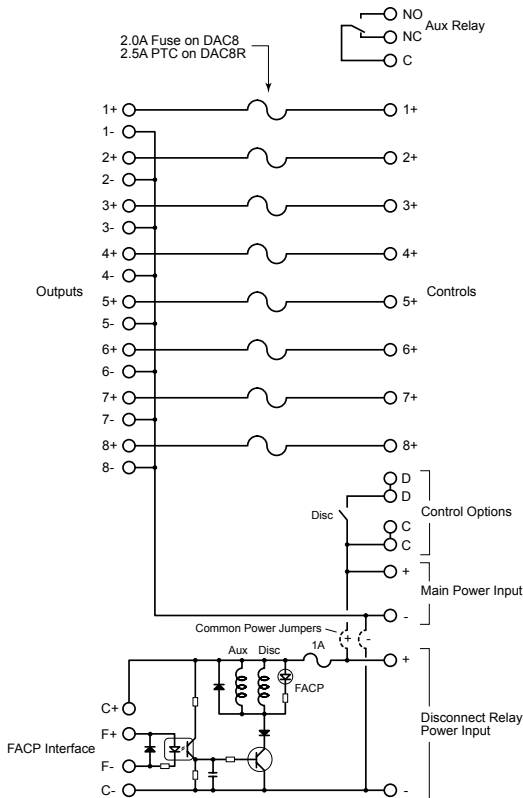

DAC8 / DAC8R Schematic Diagram

Master-Slave FACP Interface Wiring with NC Fire Alarm Contact

(Interface wiring is fused by first DAC8 Control Power Fuse)

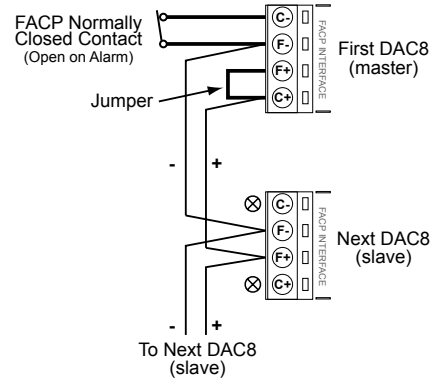

Alternate Master-Slave FACP Interface Wiring with NC Fire Alarm Contact

(Interface wiring is fused by each DAC8 Control Power Fuse)

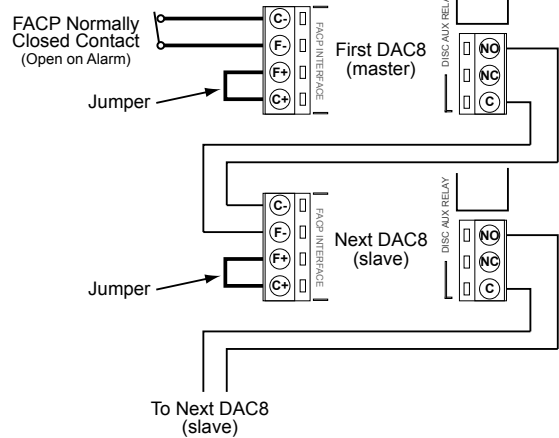

FACP Interface Wiring with FACP Voltage (12-24vdc)

(Interface wiring is fused by FACP Power Source)

- This wiring method has not been evaluated by UL. -

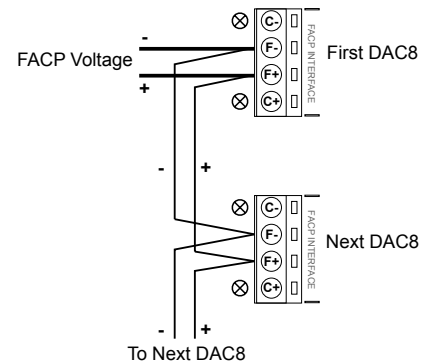

DAC8 / DAC8R Direct Access Controller

Micro-Series

DAC8 / DAC8R Specifications

- Indoor Temperature Range: 0° C. to +49°C.
- Electrical
 - Maximum Main Power Input Voltage AC/DC: 30V
 - Maximum Total Output Current: 8A
 - Maximum Recommended Current per Output: 2.5A
 - Disconnect Relay Power Input: 12 or 24VDC (-10%, +30%)
 - Disconnect Relay Power Input Fuse: 1A fuse or PTC
 - FACP Interface Maximum Current Draw: 10 mA
 - Maximum Current Draw of Disconnect Relay Power Input: 70 mA
- Connections: Captive Screw Terminals for 14-22AWG Wire
 PTC Outputs: 2.5A PTC Resettable Devices included (DAC8R)
 Fuse Outputs: 2.0A 3AG-type Fuses included (DAC8)
- Other Features
 - Fail-Safe or Fail-Secure selectable per output
 - Outputs and Relay Control power can be common or separately powered
 - Red LED indicator for Disconnect Relay status
 - Disconnect Aux Relay terminals for alarm monitoring
- Size: 3.00 (76.20) wide by 6.00 (152.40) [inches (mm)]
- Mounting: (4) 1/4 inch high nylon standoffs included
- Models (Use these part numbers when ordering)
 - for 12VDC Disconnect Relay Power Input**
 - DAC8-12 Includes 8 replaceable 2.0A fuses, 12VDC relays
 - DAC8R-12 Includes 8 PTC resettable 2.5A fuses, 12VDC relays
 - for 24VDC Disconnect Relay Power Input**
 - DAC8-24 Includes 8 replaceable 2.0A fuses, 24VDC relays
 - DAC8R-24 Includes 8 PTC resettable 2.5A fuses, 24VDC relays
- Other related BASE products
 - PM8 / PM8R Power Distribution Module
 - MAC8 / MAC8R Multi Access Controller
 - LVPC Custom Prewired Power Cabinet Assemblies

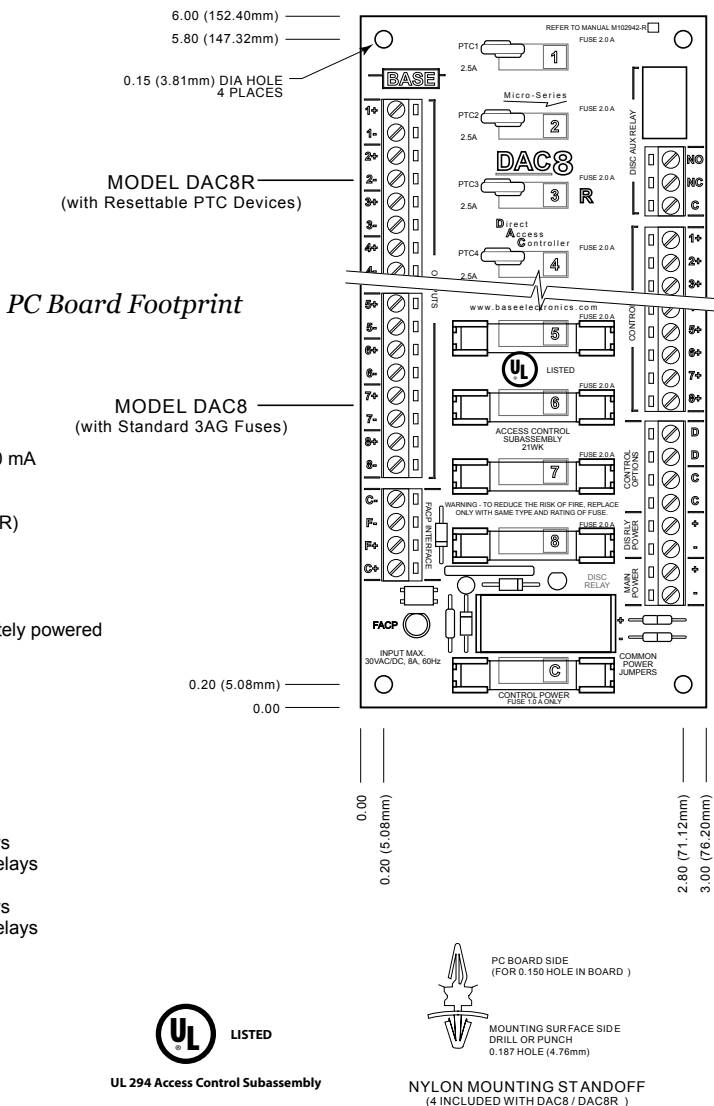

UL 294 Access Control Subassembly

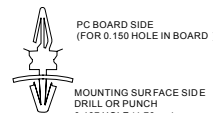

NYLON MOUNTING STANDOFF (4 INCLUDED WITH DAC8 / DAC8R)

The information in this manual is believed to be accurate in all respects. However, BASE Electronics cannot assume responsibility for any consequences resulting from the use thereof. The information contained herein is subject to change and BASE Electronics may issue a revision to incorporate such changes at any time.

Understanding PTC Resettable Fuses

When an overcurrent condition occurs on a PTC protected output, the PTC device will heat and its resistance will increase, thus limiting current flow. When tripped, though current will be reduced, the circuit is not open (like it is with a blown fuse), and a digital meter on the output will likely and normally indicate some voltage and current flow, which is necessary to maintain the tripped condition of the PTC. Trip time may vary from milliseconds to even minutes depending on the nature of the overcurrent condition.

Find other Power System Design Guides and Tech Tips at...

www.baseelectronics.com

Limited Warranty

The DAC8 / DAC8R is warranted by BASE Electronics against manufacturing defects in materials and workmanship for a period of 2 years from date of purchase. During this period, any warranty repair required will be made at no charge for parts or labor. This warranty does not apply to any work or materials provided by any outside persons or technicians involved in the installation, unauthorized repair, connection, or testing of this product. This warranty does not cover any damage or failure caused by or attributable to Acts of God, abuse, misuse, improper or abnormal usage, faulty or improper installation or maintenance, neglect or accident. BASE Electronics is not responsible or liable for any special, consequential or indirect damages resulting from or in connection with the use or performance of this product as pertaining to economic loss, property loss, costs for removal or installation, or loss of revenues or profit. Except as provided herein, BASE Electronics makes no expressed or implied warranties. The duration of product performance for its intended purpose is limited to the duration set forth herein.

For Warranty or other repair, send the product postage prepaid to BASE Electronics and include Sender's name, company, address, phone and brief problem description. BASE Electronics will notify sender of any required repair costs not covered under this warranty prior to making such repairs.

This Warranty gives you specific legal rights. You may have other rights that vary from state to state.

