

BASE

Selectable Series

LV-8RS-N

Low Voltage Power Distribution Module

Installation and Operation Manual



BASE Electronics, Inc.

2856-C Janitell Road • Colorado Springs, CO 80906 • (719) 540-9697 • Fax (719) 540-9698

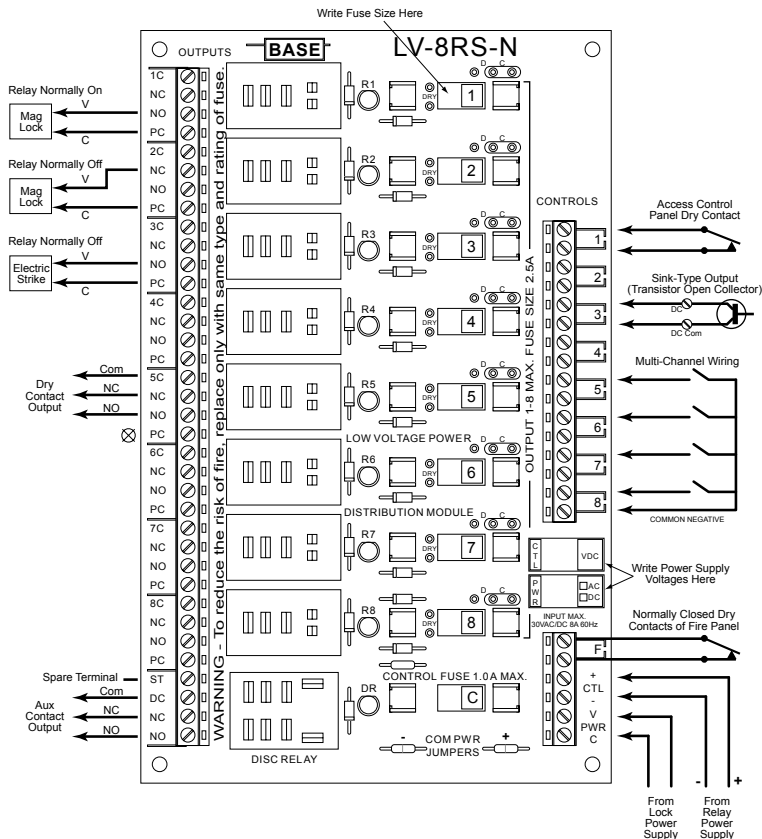

Figure 1 - LV-8RS-N Wiring Diagram

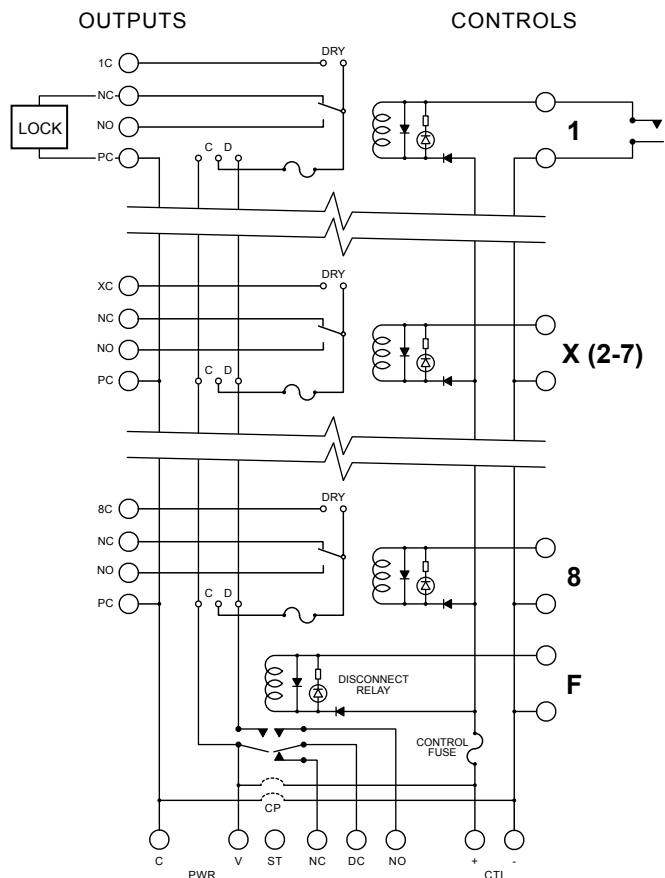

Figure 2 - LV-8RS-N Schematic Diagram

LV-8RS-N Specifications

- Indoor Temperature Range: -25° C. to +70° C.
- Electrical
 - Maximum Voltage AC/DC: 30V
 - Maximum Total Current: 8A
 - Maximum Recommended Current per Output: 2.5A
 - Maximum Total Relay Coil Current Draw: 1A
 - Connections: Captive Screw Terminals for #14 to #22AWG Wire
- Size: 5.00" wide by 8.00" long by 2.50 maximum height (inches) with relays installed.
- Mounting: (4) 3/8 inch high nylon standoffs included
- Indicators, Controls and Jumpers
 - Red LED Indicators at all 9 relay positions
 - Common Power - and +, Cut = Separate Relay Control Power, Uncut = Common Power
 - Mode Jumpers (Each Output), C = Continuously Powered, D = Disconnect, DRY = Dry Contact
- Special Features
 - Fail Safe / Fail Secure / Dry Contact Mode Jumper per Output
 - Power Disconnect Relay Socket with Auxiliary Contact Terminals
 - 8 Output Isolation Relays with LED Indicators



BASE Electronics, Inc.

2856-C Janitell Road • Colorado Springs, CO 80906 • (719) 540-9697 • Fax (719) 540-9698

Limited Warranty

The LV-8RS-N Low Voltage Power Distribution Module is warranted by BASE Electronics against manufacturing defects in materials and workmanship for a period of 2 years from date of purchase. During this period, any warranty repair required will be made at no charge for parts or labor. This warranty does not apply to any work or materials provided by any outside persons or technicians involved in the installation, unauthorized repair, connection, or testing of this product. This warranty does not cover any damage or failure caused by or attributable to Acts of God, abuse, misuse, improper or abnormal usage, faulty or improper installation or maintenance, neglect or accident. BASE Electronics is not responsible or liable for any special, consequential or indirect damages resulting from or in connection with the use or performance of this product as pertaining to economic loss, property loss, costs for removal or installation, or loss of revenues or profit. Except as provided herein, BASE Electronics makes no expressed or implied warranties. The duration of product performance for its intended purpose is limited to the duration set forth herein.

For Warranty or other repair, send the product postage prepaid to BASE Electronics and include Sender's name, company, address, phone and brief problem description. BASE Electronics will notify sender of any required repair costs not covered under this warranty prior to making such repairs.

This Warranty gives you specific legal rights. You may have other rights that vary from state to state.

LV-8RS-N

Low Voltage Power Distribution Module

The LV-8RS-N distributes power from a low voltage power source to 8 fused outputs through 8 Output Isolation Relay sockets -or- can be configured to provide up to 8 dry contact relay outputs. The -N model provides for negative or sink control of each output relay by an Access Control system. Output devices can be powered separately from the control relays by configuring Common Power Jumpers. A 2-pole Disconnect Relay socket is provided and easily interfaces with Fire, Life Safety or Alarm Panels to provide Emergency Power Disconnect. Relay auxiliary contact terminals are provided for alarm monitoring of the Disconnect feature.

Each of the 8 outputs includes a removable jumper clip easily configurable for one of 3 modes of operation:

- 1) D position - Disconnect or Fail Safe operation of the output.
This means the output is disconnected by the Disconnect Function.
- 2) C position - Continuous or Fail Secure operation of the output.
This means the output is unaffected by the Disconnect Function.
- 3) DRY position - A jumper in this position configures the output for dry relay contacts. Since an output in this mode is not powered, the jumper blocks the installation of a fuse in the corresponding output fuseholder.

The LV-8RS-N includes red LED indicators at each of the 9 relay positions for identification of energized relays.

The module is 5.00" wide x 8.00" long. The installed height with relays is 2.50". Standoffs are included for mounting the circuit board in a user-supplied enclosure. Relays and 3AG-type Fuses are provided separately. To meet UL Listing requirements, the relays selected should be Idec Corp., P/N RH1B-U SPDT or P/N RH2B-U, DPDT, 12vdc or 24vdc.

*** WARNING ***

Turn off all power feeding the module terminals before servicing or changing input/output wiring, removing or reinstalling fuses, relays, or jumpers. Failure to observe this warning may cause electrical shock hazard or may damage internal or external circuit components.

The information in this manual is believed to be accurate in all respects. However, BASE Electronics cannot assume responsibility for any consequences resulting from the use thereof. The information contained herein is subject to change and BASE Electronics may issue a revision to incorporate such changes at any time.

INSTALLATION

Locate the unit inside a UL Listed NEMA 1 enclosure (such as a BASE LVPC Low Voltage Power Cabinet) close to the source power supply. Drill (4) 0.187" diameter holes to match the (4) corner holes in the printed circuit board. Push the nylon standoffs supplied into each hole and snap the module into place.

Note: To comply with UL294 - Standard For Safety - Access Control System Units and the limitations of the UL product Listing, the LV Module should be located within the same room as the associated Access Control equipment and interconnect cabling to the LV Module inputs. The unit is to be powered from a Class 2 Power-Limited UL Listed Source.

POWER SUPPLY WIRING

Common Relay Control and Output Voltage If the output devices require a DC operating voltage, the Common Power Jumpers can remain intact and only one DC power supply needs to be connected to the PWR input terminals. In this mode, the DC operating voltage of the control relays, output devices and the power supply must match. Example: Output devices = 24VDC Maglocks, Power Supply = 24VDC, Relays must also be 24VDC.

Separate Relay Control and Output Voltages

By cutting the Common Power Jumpers, two separate power supplies of like or different voltages may be used to power the output devices and control relays. The relay power supply must be DC. The output power supply can be either AC or DC.

Connect the power supply input leads to the terminal strip at the lower right side of the module as shown in Figure 1. Use a minimum of 18AWG copper conductors for this wiring and keep the length to the power supply as short as possible.

The values of the CTL and PWR voltages may be written on the white areas provided in the lower right side of the module for easy future reference.

| Output Power Supply | Relay Power Supply | Run Power Supply Wiring To: | Common Power Jumpers |
|---------------------|--------------------|-----------------------------|----------------------|
| DC-1 | DC-1 | PWR | Uncut |
| DC-1 | DC-2 | (both PWR and CTL) | Cut |
| AC | DC | (both PWR and CTL) | Cut |

OUTPUT MODE CONFIGURATION

Each module includes 8 jumper pins for configuring the mode of operation for each of the 8 outputs. They are installed in the C position from the factory.

C position - Continuous Power Mode The output is continuously powered and unaffected by the Power Disconnect feature. If all 8 outputs will be configured in the C position, there is no need to install a Disconnect Relay in the 2-pole socket.

D position - Disconnect Mode The output power will be disconnected by the Disconnect Relay when the Fire Panel Interface control circuit is opened. A 2-pole Disconnect Relay must be installed in the socket provided.

DRY position - Dry Contact Mode The output becomes a dry Form C output. The output is not powered or affected by the Power Disconnect feature. Since an output in this mode is not powered, the jumper blocks the installation of a fuse in the corresponding output fuseholder.

POWER DISCONNECT WIRING

A socket is provided for a 2-pole relay that is used to disconnect the output power PWR during facility emergencies. The relay is DC powered from the power feeding the CTL terminals. Normally closed dry contacts of a fire or life safety system panel are used to control the disconnect relay at the 'F' terminals. The alarm contact should be rated for the current required by the relay selected (normally less than 50mA at 12VDC).

The auxiliary output contacts of the Disconnect Relay can be monitored. Note that the terminals designated NO and NC (shown in Figure 1) stand for Normally Open and Normally Closed when the relay is de-energized. The terminal marked ST is a Spare Terminal available for termination of an end-of-line resistor if needed.

OUTPUTS AND CONTROLS

Add the operating current ratings for each device to be powered from one output to determine the expected operating current flow. Install a fuse for the output that will trip when this value is exceeded. The value of the fuse selected for each output may be written on the white area below the fuse for easy future reference.

Example A: Output 1 - (1) magnetic lock
operating current = 0.29A at 12 VDC
Install fuse rated just greater than 0.29A = 3/8A or 1/2A

Example B: Output 2 - (4) deadbolt locks
operating current = (4 x 0.40A) = 1.6A
Install fuse rated just greater than 1.6A = 2A

Wiring to output devices connects to the OUTPUTS terminals. Four terminals are provided for each output as follows;

- #C = output relay Common terminal when in DRY mode
spare terminal when in C or D modes.
- NC = output relay Normally Closed terminal, powered when fuse is installed in C or D modes, nonpowered and dry when in DRY mode.
- NO = output relay Normally Open terminal, powered when fuse is installed in C or D modes, nonpowered and dry when in DRY mode.
- PC = output power PWR Common terminal in any mode.

Add the operating current ratings for each control relay and install a control fuse that will trip when this value is exceeded. The value of the fuse selected may be written on the white area below the fuse for easy future reference.

When powering devices over considerable distances, the cabling resistance may be so high that the voltage available at the device drops to an unacceptable level. To prevent this from occurring, the system cabling should be designed with adequate sized conductors.

Suggested wiring methods for OUTPUTS and CONTROLS are shown in Figure 1.

All fuses must be type 3AG. Output Fuses must be 2.5A maximum or less. Control Fuse must be 1.0A Maximum. Fuses are ordered separately - specify desired rating when ordering.

LIGHTNING, TRANSIENT AND NOISE SUPPRESSION

Lightning or transient suppression devices may be installed at the LV-8RS-N output terminals to protect control equipment from induced voltages. A multi-screw, solid ground bar should be installed vertically next to the output side of the module for connection of metal oxide varistors, transient suppression diodes, etc. If shielded cable is used for output wiring, shield drain wires can be connected to the ground bar for line noise suppression. Run a minimum #14AWG green stranded ground wire from the ground bar to the closest Service Ground. Grounding bars of the type mentioned above can be separately supplied by BASE Electronics.