

# MAC4 / MAC4R Multi Access Controller

MANUAL M102943-R 4/07

Installation and Operations Manual

**BASE**

Page 1 of 4

Micro-Series

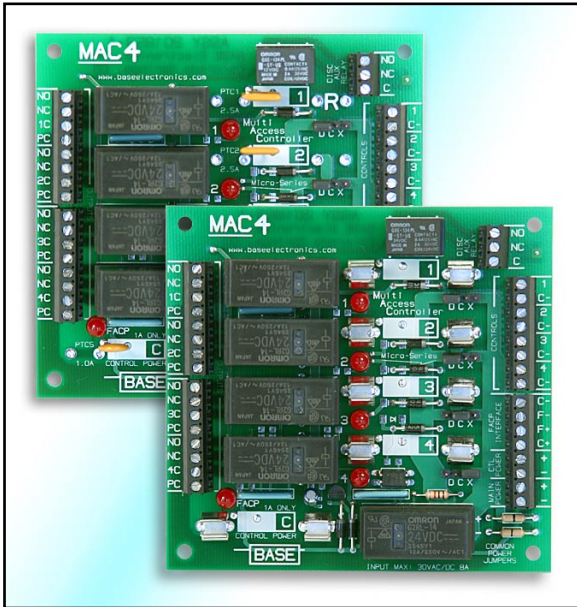

## Features

- Distributes Door Lock Power to 4 Fused or PTC Outputs through Isolation Relays
- Uses low-power Depluggable / Replaceable Relays
- Fail-Safe, Fail-Secure, Dry Contact or Fused-Output-Only selectable per Output
- FACP Interface for Emergency Power Disconnect
- Replaceable Disconnect Relay with Aux Contact
- Small Footprint PCB - 4.1" w x 3.9" h
- Includes Mounting Hardware

<b>MAC4</b>	Includes (4) 2.0 A replaceable fuses, standard 3AG (1/4" x 1 1/4")
<b>MAC4R</b>	Includes (4) 2.5 A PTC auto-resettable fuses

**! WARNING** Turn off all power feeding the module terminals before servicing or changing input/output wiring, removing or replacing fuses, etc. Failure to observe this warning may cause electrical shock hazard or may damage internal or external circuit components.

Install in accordance with all applicable sections of the National Electrical Code and other State or Local Regulations.



UL 294 Access Control Subassembly

## INSTALLATION

Locate the unit inside a UL Listed enclosure, such as a BASE LVPC Power Cabinet or Econo•Box, close to the source power supply. Drill or punch (4) 0.187" diameter holes (3/16) to match the (4) corner holes in the printed circuit board. Push the nylon standoffs supplied into each hole and snap the module into place.

Note: To comply with UL294 - Standard for Safety - Access Control System Units and the limitations of the product UL Listing, the module should be located within the same room as the associated Access Control equipment and interconnect cabling to the module control inputs. The unit is to be powered from a Class 2 Power-Limited UL Listed Source.

## POWER SUPPLY WIRING

### Common Power Supply for Outputs and Disc Relay Control

Do not cut Common Power Jumpers. Connect 12 or 24VDC power supply input leads to the **MAIN POWER** input terminals at the lower right side of the module. See Power Input Wiring Diagram 1.

### Separate Power Supplies for Outputs and Disc Relay Control

Cut both Common Power Jumpers. Connect 12 or 24VDC Relay Control power supply input leads to the **CTL POWER** input terminals at the lower right side of the module.

Connect 12-24VAC/DC Door Lock power supply input leads to the **MAIN POWER** input terminals at the lower right side of the module. See Power Input Wiring Diagram 2.

[www.baseelectronics.com](http://www.baseelectronics.com)

Go!

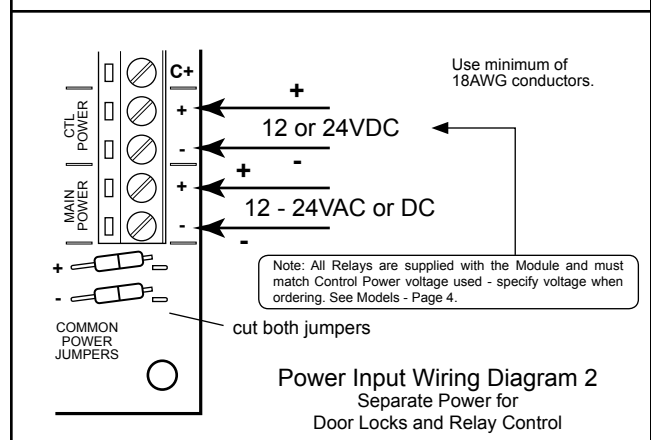
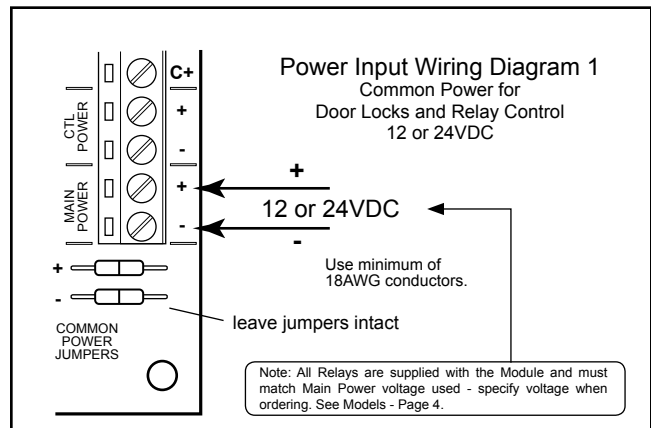

# MAC4 / MAC4R Multi Access Controller

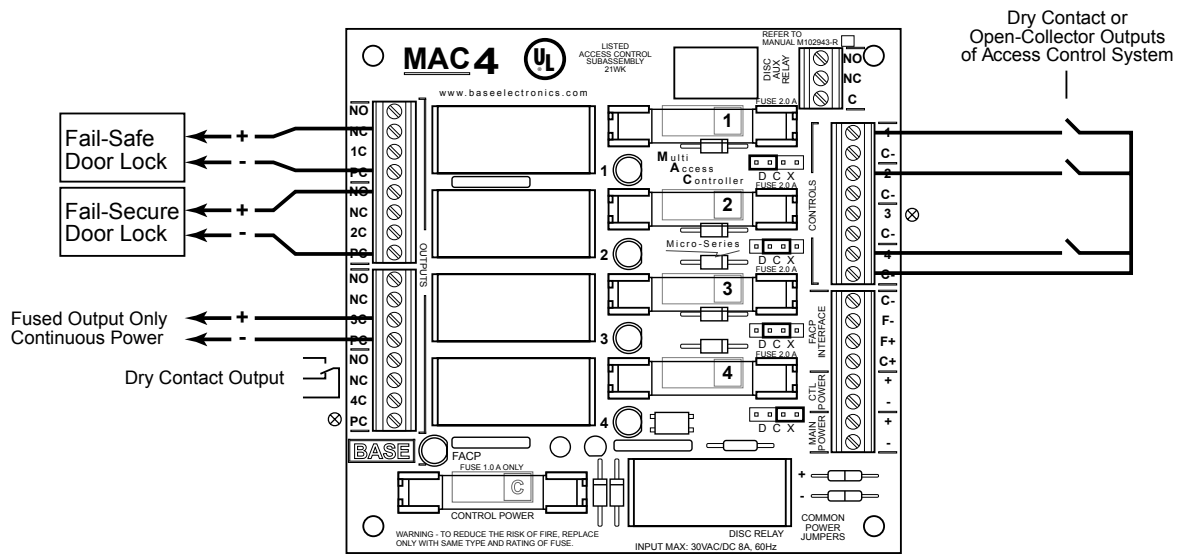

Note: All relay contact legends are shown with the relay in the de-energized state.

## SET OUTPUT CONFIGURATION JUMPERS

<b>D = Disconnect</b>		Select D for Fail-Safe Output. Power is Disconnected when FACP Interface is in alarm. (Disconnect Relay de-energized)
<b>C = Continuous</b>		Select C for Fail-Secure Output. Power is Continuous and unaffected by FACP Interface.
<b>X = Dry Contact</b>		Select X for Dry Form-C Contact. Fuse may be removed or may be left in place. PC Output terminal not used.

## OUTPUT AND CONTROL WIRING EXAMPLES ABOVE

In each example, note configuration jumper setting. Wiring is the same for MAC4 (shown) or MAC4R.

**Channel 1** is set up for Fail-Safe Locks. Relay 1 is controlled by a normally-open contact and energizes to unlock the door. This output will lose power when the Disconnect Relay de-energizes on FACP interface alarm.

**Channel 2** is the classic setup for a Fail-Secure Lock. Relay 2 is controlled by a normally-open contact and energizes to unlock the door.

**Channel 3** shows an example of a continuous power Fused-Output-Only. No control contact is wired, therefore the relay is not being used and can be removed and saved as a spare if desired. The fused-output-only will function whether or not a relay is present.

If the configuration jumper is moved to the D position, the output becomes a Fail-Safe Power Fused-Output-Only and will lose power when the Disconnect Relay de-energizes on FACP interface alarm.

**Channel 4** shows the setup for a Dry Contact Output. Just place the jumper in the X position. The output contact will be dry whether or not a fuse or PTC is installed.

## CONTROL POWER FUSE

The **CONTROL POWER** fuse protects the relay control circuitry and components. Replace only with a 1 Amp fuse or less. Maximum control circuitry power consumption with all relays energized is 350 mA (at 12VDC).

## DISCONNECT RELAY, AUX RELAY AND TERMINALS

The Disconnect Relay is operated by the FACP Interface. When the FACP Interface is normal, this relay will be on and will de-energize to drop power for Fail-Safe output devices when the FACP is in alarm. The Red **FACP** LED lights when this relay is energized.

# MAC4 / MAC4R Multi Access Controller

A Disconnect Aux Relay is also provided at the upper right and mirrors the operation of the main Disconnect Relay. Terminals of the Aux relay dry contacts are provided and can be monitored to sense when the Disconnect Relay has changed state. Aux Relay contacts are rated at 2 Amps.

## FACP INTERFACE WIRING AND OPTIONS

Choose the FACP Interface wiring method at right that is appropriate for your installation. If only one MAC4 module is being used, then wiring shown to the next module(s) can be ignored. Maximum current draw of FACP Interface circuitry (F+ and F- terminals) is 10 mA.

## FINAL CHECKS BEFORE POWER UP

Before powering the unit, check all wiring and verify that the Disconnect and Aux relays are of the proper voltage and seated in their sockets. Output and Disconnect Relay sockets include a simple plastic retainer clip which should be used to properly secure the relay pins in the socket. The Aux relay fits well enough in its socket to eliminate the need for a retaining clip.

## RELAY REPLACEMENT

All Relays are depluggable and replaceable. Inexpensive replacements are available from several manufacturers and are stocked by BASE. Specify Relay Voltage when ordering - 12 or 24vdc.

## FUSE REPLACEMENT

Replace output fuses only with similar 3AG-type fuses, slow or fast blow, with a current trip rating of 2.0 Amps or less if desired. Replace Control Fuse only with 3AG-type 1.0 Amp. fuse.

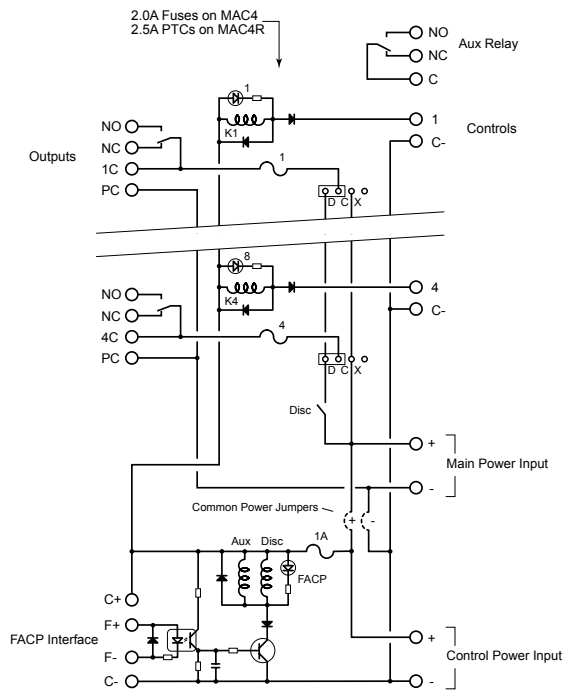

MAC4 / MAC4R Schematic Diagram

## Master-Slave FACP Interface Wiring with NC Fire Alarm Contact

(Interface wiring is fused by first MAC4 Control Power Fuse)

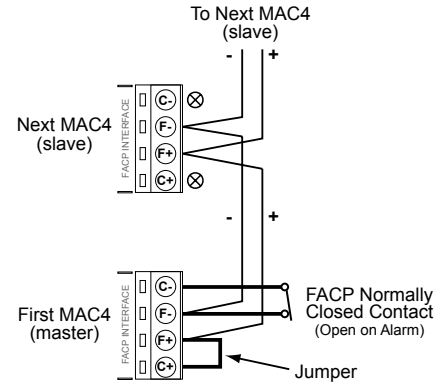

## Alternate Master-Slave FACP Interface Wiring with NC Fire Alarm Contact

(Interface wiring is fused by each MAC4 Control Power Fuse)

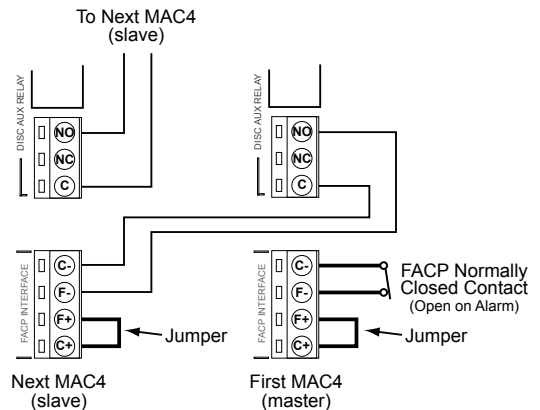

## FACP Interface Wiring with FACP Voltage (12-24vdc)

(Interface wiring is fused by FACP Power Source)

- This wiring method has not been evaluated by UL. -

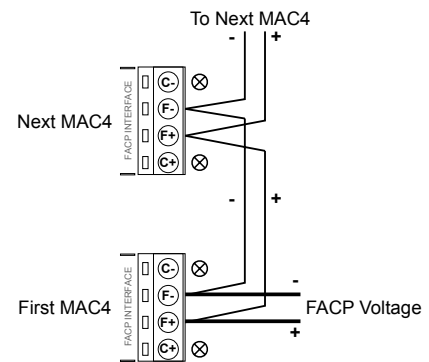

# MAC4 / MAC4R Multi Access Controller

MANUAL M102943-R 4/07

Page 4 of 4

Micro-Series



UL 294 Access Control Subassembly

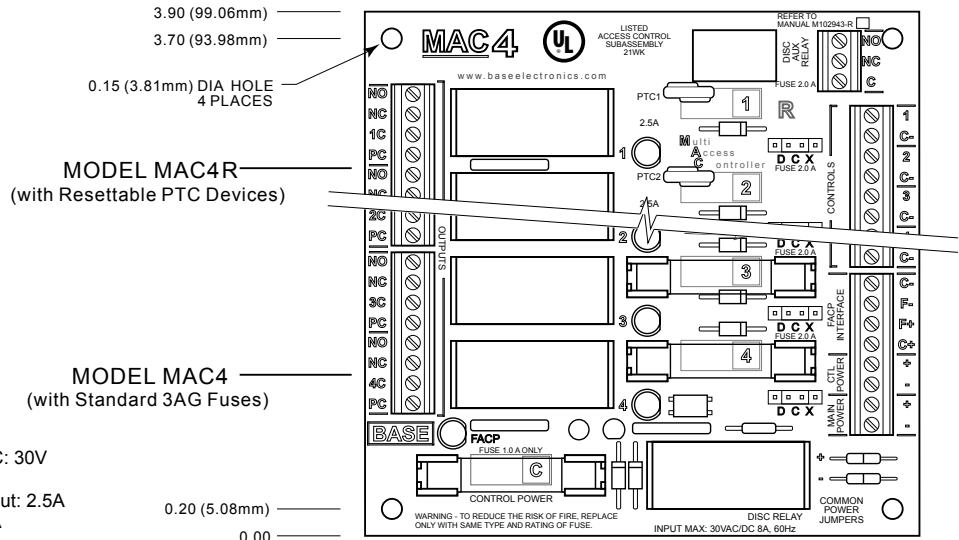

## MAC4 / MAC4R Specifications

- Indoor Temperature Range: 0° C. to +49°C.

### Electrical

Maximum Main Power Input Voltage AC/DC: 30V  
Maximum Total Current: 8A  
Maximum Recommended Current per Output: 2.5A  
Output and Disc Relay Contact Rating: 12A

Control Power Input: 12 or 24VDC (-10%, +30%)  
Control Power Input Fuse: 1A fuse or PTC  
FACP Interface Maximum Current Draw: 10 mA  
Maximum Current Draw per Relay: 35 mA  
Maximum Current Draw of Control Power Input: 200 mA

Connections: Captive Screw Terminals for #14 to #22AWG Wire  
PTC Outputs: 2.5A PTC Resettable Devices included (MAC4R)  
Fuse Outputs: 2.0A 3AG-type Fuses included (MAC4)

### Other Features

Fail-Safe, Fail-Secure, Dry Contact, or Fused-Output-only selectable per output  
All relays are low-cost, depluggable and replaceable  
Outputs and Relay Control power can be commonly or separately powered  
5 Red LED indicators for relay status  
Disconnect Relay Aux terminals for alarm monitoring

- Size: 4.12 (104.77) wide by 3.90 (99.06) high [ inches (mm) ]
- Mounting: (4) 1/4 inch high nylon standoffs included

### Models (Use these part numbers when ordering)

#### for 12VDC Control Power Input

MAC4-12 Includes 4 replaceable 2.0A fuses, 12VDC relays

MAC4R-12 Includes 4 PTC resettable 2.5A fuses, 12VDC relays

#### for 24VDC Disconnect Relay Power Input

MAC4-24 Includes 4 replaceable 2.0A fuses, 24VDC relays

MAC4R-24 Includes 4 PTC resettable 2.5A fuses, 24VDC relays

### Other related BASE products

PM8 / PM8R Power Distribution Module  
DAC8 / DAC8R Direct Access Controller  
LVPC Custom Prewired Power Cabinet Assemblies

### Understanding PTC Resettable Fuses

When an overcurrent condition occurs on a PTC protected output, the PTC device will heat and its resistance will increase, thus limiting current flow. When tripped, though current will be reduced, the circuit is not open (like it is with a blown fuse), and a digital meter on the output will likely and normally indicate some voltage and current flow, which is necessary to maintain the tripped condition of the PTC. Trip time may vary from milliseconds to even minutes depending on the nature of the overcurrent condition.

Find other Power System Design Guides and Tech Tips at...

[www.baseselectronics.com](http://www.baseselectronics.com)

### Limited Warranty

The MAC4 / MAC4R is warranted by BASE Electronics against manufacturing defects in materials and workmanship for a period of 2 years from date of purchase. During this period, any warranty repair required will be made at no charge for parts or labor. This warranty does not apply to any work or materials provided by any outside persons or technicians involved in the installation, unauthorized repair, connection, or testing of this product. This warranty does not cover any damage or failure caused by or attributable to Acts of God, abuse, misuse, improper or abnormal usage, faulty or improper installation or maintenance, neglect or accident. BASE Electronics is not responsible or liable for any special, consequential or indirect damages resulting from or in connection with the use or performance of this product as pertaining to economic loss, property loss, costs for removal or installation, or loss of revenues or profit. Except as provided herein, BASE Electronics makes no expressed or implied warranties. The duration of product performance for its intended purpose is limited to the duration set forth herein.

For Warranty or other repair, send the product postage prepaid to BASE Electronics and include Sender's name, company, address, phone and brief problem description. BASE Electronics will notify sender of any required repair costs not covered under this warranty prior to making such repairs.

This Warranty gives you specific legal rights. You may have other rights that vary from state to state.

© Copyright 2006-2007 BASE Electronics, Inc.

**BASE**