

Figure 1 - LV-8RCL-N Wiring Diagram

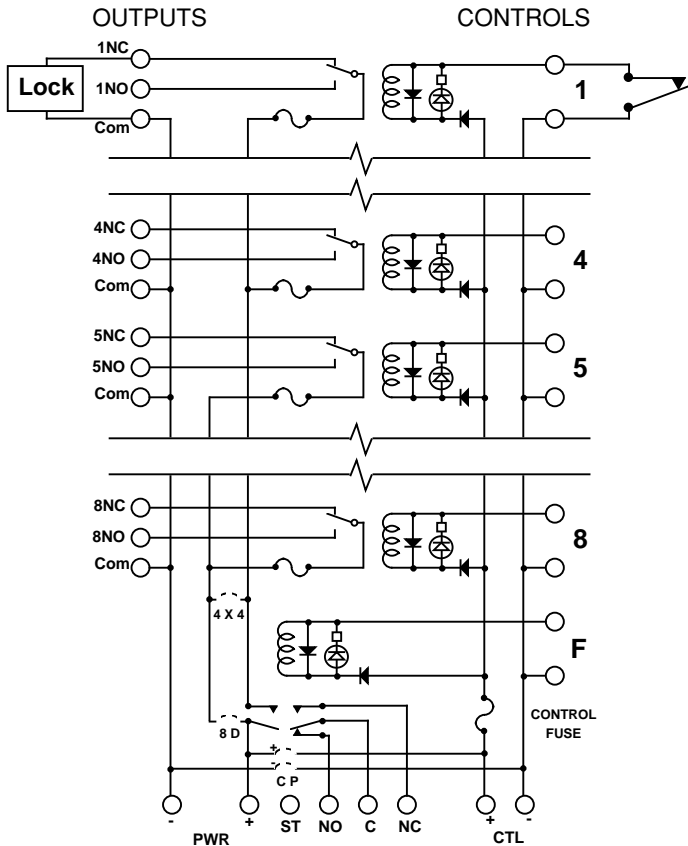

Figure 2 - LV-8RCL-N Schematic Diagram

# BASE

## LV-8RCL-N

### Low Voltage Power Distribution Module

#### Installation and Operation Manual



**BASE Electronics, Inc.**

2856-C Janitell Road • Colorado Springs, CO 80906 • (719) 540-9697 • Fax (719) 540-9698

#### LV-8RCL-N Specifications

- Indoor Temperature Range: -25° C. to +70° C.



- Electrical
  - Maximum Voltage AC/DC: 30V
  - Maximum Total Current: 8A
  - Maximum Recommended Current per Output: 2.5A
  - Maximum Total Relay Coil Current Draw: 1A
  - Connections: Captive Screw Terminals for #14 to #22AWG Wire

- Size: 5.00" wide by 8.00" long by 2.50 maximum height (inches) with relays installed.
- Mounting: (4) 3/8 inch high nylon standoffs included

- Indicators, Controls and Jumpers
  - Red LED Indicators at all 9 relay positions
  - Common Power - and +, Cut = Separate Relay Control Power, Uncut = Common Power
  - Mode Jumpers Uncut = 8 Continuous, Cut 8D = w/Disconnect, Cut 4x4 = 4x4 Mode

- Special Features
  - Mode Jumpers, 4x4 Mode
  - Power Disconnect Relay Socket with Auxiliary Contact Terminals
  - 8 Output Isolation Relays with LED Indicators

**BASE Electronics, Inc.**

2856-C Janitell Road • Colorado Springs, CO 80906 • (719) 540-9697 • Fax (719) 540-9698

#### Limited Warranty

The LV-8RCL-N Low Voltage Power Distribution Module is warranted by BASE Electronics against manufacturing defects in materials and workmanship for a period of 2 years from date of purchase. During this period, any warranty repair required will be made at no charge for parts or labor. This warranty does not apply to any work or materials provided by any outside persons or technicians involved in the installation, unauthorized repair, connection, or testing of this product. This warranty does not cover any damage or failure caused by or attributable to Acts of God, abuse, misuse, improper or abnormal usage, faulty or improper installation or maintenance, neglect or accident. BASE Electronics is not responsible or liable for any special, consequential or indirect damages resulting from or in connection with the use or performance of this product as pertaining to economic loss, property loss, costs for removal or installation, or loss of revenues or profit. Except as provided herein, BASE Electronics makes no expressed or implied warranties. The duration of product performance for its intended purpose is limited to the duration set forth herein.

For Warranty or other repair, send the product postage prepaid to BASE Electronics and include Sender's name, company, address, phone and brief problem description. BASE Electronics will notify sender of any required repair costs not covered under this warranty prior to making such repairs.

*This Warranty gives you specific legal rights. You may have other rights that vary from state to state.*

## LV-8RCL-N Low Voltage Power Distribution Module

The LV-8RCL-N distributes power from a low voltage power source to 8 fused outputs through 8 Output Isolation Relay sockets. Terminals are provided for negative or sink control of each output relay by an Access Control system. Output devices can be powered separately from the control relays by configuring Common Power Jumpers. A 2-pole Disconnect Relay socket is provided and easily interfaces with Fire, Life Safety or Alarm Panels to provide Emergency Power Disconnect. Relay auxiliary contact terminals are provided for alarm monitoring of the Disconnect feature.

Each unit includes jumpers configurable for 3 modes of operation:

- 1) 8 outputs that are disconnected by the Disconnect Relay
- 2) 8 outputs that are unaffected by the Disconnect Relay
- 3) 4 x 4 mode (Outputs 1-4 = Mode 1, Outputs 5-8 = Mode 2)

The LV-8RCL-N includes red LED indicators at each of the 9 relay positions for identification of energized relays.

The module is 5.00" wide x 8.00" long. The installed height with relays is 2.50". Standoffs are included for mounting the circuit board in a user-supplied enclosure. Relays and 3AG-type Fuses are provided separately. To meet UL Listing requirements, the relays selected should be Idec Corp., P/N RH1B-U SPDT or P/N RH2B-U, DPDT, 12vdc or 24vdc.

\*\*\* WARNING \*\*\*

Turn off all power feeding the module terminals before servicing or changing input/output wiring, removing or reinstalling fuses or relays, or cutting jumpers. Failure to observe this warning may cause electrical shock hazard or may damage internal or external circuit components.

The information in this manual is believed to be accurate in all respects. However, BASE Electronics cannot assume responsibility for any consequences resulting from the use thereof. The information contained herein is subject to change and BASE Electronics may issue a revision to incorporate such changes at any time.

### INSTALLATION

Locate the unit inside a UL Listed NEMA 1 enclosure (such as a BASE LVPC Low Voltage Power Cabinet) close to the source power supply. Drill (4) 0.187" diameter holes to match the (4) corner holes in the printed circuit board. Push the nylon stand-offs supplied into each hole and snap the module into place.

Note: To comply with UL294 - Standard For Safety - Access Control System Units and the limitations of the UL product Listing, the LV Module should be located within the same room as the associated Access Control equipment and interconnect cabling to the LV Module inputs.

### POWER SUPPLY WIRING

**Common Relay Control and Output Voltage** If the output devices require a DC operating voltage, the Common Power Jumpers can remain intact and only one DC power supply needs to be connected to the PWR input terminals. In this mode, the DC operating voltage of the control relays, output devices and the power supply must match. Example: Output devices = 24VDC Maglocks, Power Supply = 24VDC, Relays must be 24VDC.

#### Separate Relay Control and Output Voltage

By cutting the Common Power Jumpers, two separate power supplies of like or different voltages can be used to power the output devices (use the PWR terminals) and control relays (use the CTL terminals). The CTL power supply must be DC while the PWR power supply can be either AC or DC.

Connect the power supply input leads to the terminal strip at the lower left side of the module as shown in Figure 1. Use a minimum of 18AWG copper conductors for this wiring and keep the length to the power supply as short as possible.

### MODE CONFIGURATION

Each module includes 8D and 4X4 jumpers for configuring the mode of operation.

**Continuous Power Mode** When no jumpers are cut, the outputs are continuously powered and unaffected by the Disconnect feature. If Emergency Power Disconnect is not needed, do not cut any jumpers and do not install a 2-pole relay at the Disconnect Relay socket.

**8 Disconnect Mode** When the 8D jumper is cut, all 8 outputs will be disconnected by the Disconnect Relay when the Fire Panel Interface control circuit is opened. A 2-pole Disconnect Relay must be installed in the socket provided.

**4 X 4 Mode** When the 4 X 4 Jumper is cut, outputs 1-4 will operate in the Disconnect mode and outputs 5-8 will be unaffected by the Disconnect feature. A 2-pole Disconnect Relay must be installed in the socket provided.

### POWER DISCONNECT WIRING

A socket is provided for a 2-pole relay that is used to disconnect the output power PWR during facility emergencies. The relay is DC powered from the power feeding the CTL terminals. Normally closed dry contacts of a fire or life safety system panel are used to control the disconnect relay at the 'F' terminals. The alarm contact should be rated for the current required by the relay selected (normally less than 50mA at 12VDC).

The auxiliary output contacts of the Disconnect Relay can be monitored. Note that the terminals designated NO and NC (shown in Figure 1) stand for Normally Open and Normally Closed when the relay is de-energized. The terminal marked ST is a Spare Terminal available for termination of an end-of-line resistor if needed.

### OUTPUTS AND CONTROLS

Add the operating current ratings for each device to be powered from one output to determine the expected operating current flow. Install a fuse for the output that will trip when this value is exceeded. The value of the fuse selected for each output may be written on the white area below the fuse for easy future reference.

**Example A:** Output 1 - (1) magnetic lock  
operating current = 0.29A at 12 VDC  
Install fuse rated just greater than 0.29A = 3/8A or 1/2A

**Example B:** Output 2 - (4) deadbolt locks  
operating current = (4 x 0.40A) = 1.6A  
Install fuse rated just greater than 1.6A = 2A

Add the operating current ratings for each control relay and install a control fuse that will trip when this value is exceeded. The value of the fuse selected may be written on the white area below the fuse for easy future reference.

When powering devices over considerable distances, the cabling resistance may be so high that the voltage available at the device drops to an unacceptable level. To prevent this from occurring, the system cabling should be designed with adequate sized conductors. Use the Low Voltage System Cabling Design Guide in this manual for help in obtaining the desired results. Wiring to output devices connects to the OUTPUTS terminals. Three terminals are provided for each output. 'NC' or 'NO' designates the fused output terminal. 'Com' designates the voltage Common terminal. Suggested wiring methods for OUTPUTS and CONTROLS are shown in Figure 1.

### LIGHTNING, TRANSIENT AND NOISE SUPPRESSION

Lightning or transient suppression devices may be installed at the LV-8A output terminals to protect control equipment from induced voltages. A multi-screw, solid ground bar should be installed vertically next to the output side of the module for connection of metal oxide varistors, transient suppression diodes, etc. If shielded cable is used for output wiring, shield drain wires can be connected to the ground bar for line noise suppression. Run a minimum #14AWG green stranded ground wire from the ground bar to the closest Service Ground. Grounding bars of the type mentioned above can be separately supplied by BASE Electronics.

### LOW VOLTAGE SYSTEM CABLING DESIGN GUIDE

With an improperly designed cabling system, the resistance of wire conductors may cause a voltage drop that could significantly affect the performance of the powered device. The resistance of a given length of cabling and its voltage drop at the given operating voltage can be calculated. This allows the affect on the powered device to be estimated with adjustments in conductor size implemented in the design stage.

#### Example:

A CCTV camera requires 0.29A at 24 VAC and the estimated cable length from the power supply is 800 feet. The camera specifications state that the camera will operate properly down to 21.0 VAC (a voltage drop of 3.0 volts maximum). What should be the size of the power cable conductors? From the chart below, we observe that a pair of 18AWG stranded copper conductors will have a resistance of 2 x 800 feet x 6.48 ohms/1000 feet. Using Ohm's Law:  $E = I \times R$

$$E (\text{voltage dropped}) = I (\text{the required current}) \times R (\text{the cabling resistance})$$

$$E = (0.29) \times (2 \times 800 \times (6.48/1000)) = 3.007 \text{ volts}$$

Subtracting 3.007 volts from 24VAC leaves 20.993 volts available at the camera, an unacceptable level. When 16AWG conductors are used in the equation:  $E = (0.29) \times (2 \times 800 \times (3.67/1000)) = 1.703 \text{ volts}$

Subtracting 1.703VAC from 24VAC leaves 22.297VAC available at the camera. Taking future expansion of a second camera into account, the estimator may decide to increase the conductors to #14AWG as follows:  $E = (2 \times 0.29) \times (2 \times 800 \times (2.31/1000)) = 2.14 \text{VAC dropped}$

When powering inductive devices (relay coils, electric strikes, magnetic locks, etc.), remember to install reversing diodes (DC powered) or metal oxide varistors (AC powered) at the device terminals or as recommended by the device manufacturer to counter the affect of Counter Magnetic Force (CMF).

Solid Conductors		Resistance of Copper Conductors		
Wire Gage (AWG)	Resistance (Ω/1000')	Wire Gage (AWG)	Stranding (#/AWG)	Resistance (Ω/1000')
10	1.00	10	37/26	1.11
12	1.59	12	7/20	1.45
14	2.53	14	7/22	2.31
16	4.02	16	7/24	3.67
18	6.39	18	16/30	6.48
20	10.15	20	10/30	10.32
22	16.14	22	7/30	14.74
24	25.67	24	7/32	23.30